



Driver LC 20W 350/500/700mA flexC SR ADV

advanced series

Product description

- Independent constant current LED Driver
- For luminaires of protection class I and protection class II
- For luminaires with M and MM as per EN 60598, VDE 0710 and VDE 0711
- Temperature protection as per EN 61347-2-13 C5e
- Selectable output current between 350, 500 and 700 mA
- Max. output power 20 W
- Up to 85 % efficiency
- Nominal life-time up to 50,000 h
- 5-year guarantee



Housing properties

- Casing: polycarbonate, white
- Type of protection IP20

Interfaces

- Terminal blocks: 0° screw terminals

Functions

- Overload protection
- Short-circuit protection
- No-load protection
- Overtemperature protection
- Burst protection voltage 1 kV
- Surge protection voltage 1 kV (L to N)
- Surge protection voltage 2 kV (L/N to earth)

Typical applications

- For spot light and downlight in retail and hospitality application
- For panel light and area light in office and education application



Standards, page 3

Wiring diagrams and installation examples, page 3

IP20 SELV  

Driver LC 20W 350/500/700mA flexC SR ADV

advanced series

Technical data

| | |
|--|------------------------------|
| Rated supply voltage | 220 – 240 V |
| AC voltage range | 198 – 264 V |
| Max. input current (at 230 V, 50 Hz, full load) | 0.12 A |
| Mains frequency | 50 / 60 Hz |
| Overvoltage protection | 320 V AC, 1 h |
| Max. input power | 26 W |
| Typ. power consumption (at 230 V, 50 Hz, full load) ^① | 24 W |
| Min. output power | 8.7 W |
| Max. output power | 20 W |
| Typ. efficiency (at 230 V / 50 Hz / full load) ^① | 85 % |
| λ (at 230 V, 50 Hz, full load) ^① | 0.95 |
| Output current tolerance ^② | $\pm 10 \%$ |
| Max. output current peak ^③ | \leq output current + 20 % |
| Max. output voltage | 60 V |
| THD (at 230 V, 50 Hz, full load) | $< 20 \%$ |
| Output LF current ripple (< 120 Hz) | $\pm 5 \%$ |
| Starting time (at 230 V, 50 Hz, full load) | ≤ 1.2 s |
| Turn off time (at 230 V, 50 Hz, full load) | ≤ 0.2 s |
| Hold on time at power failure (output) | 0 s |
| Ambient temperature t_a (at life-time 50,000 h) | 40 °C |
| Storage temperature t_s | -40 ... +80 °C |
| Life-time | up to 50,000 h |
| Dimensions L x W x H | 101.5 x 51 x 29.5 mm |

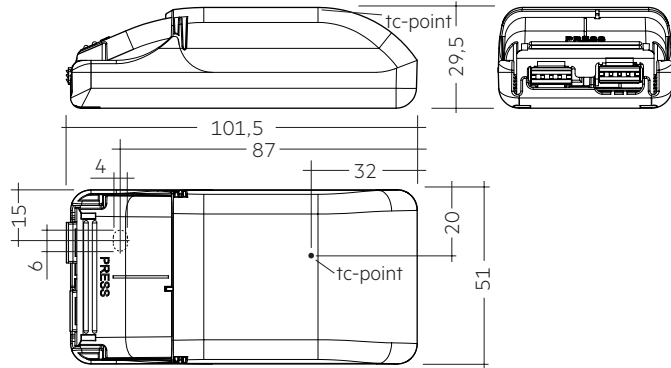

Ordering data

| Type | Article number | Packaging, carton | Packaging, pallet | Weight per pc. |
|-----------------------------------|----------------|-------------------|-------------------|----------------|
| LC 20W 350/500/700mA flexC SR ADV | 28002496 | 20 pc(s). | 1,120 pc(s). | 0.094 kg |

Specific technical data

| Type | Output current ^② | Min. forward voltage | Max. forward voltage | Max. output power | Typ. power consumption (at 230 V, 50 Hz, full load) | Typ. current consumption (at 230 V, 50 Hz, full load) | Efficiency (at 230 V, 50 Hz, full load) | Efficiency (at 230 V, 50 Hz, min. load) | Max. casing temperature t_c | Ambient temperature t_a max. |
|-----------------------------------|-----------------------------|----------------------|----------------------|-------------------|---|---|---|---|-------------------------------|--------------------------------|
| LC 20W 350/500/700mA flexC SR ADV | 350 mA | 25 V | 50.0 V | 17.5 W | 21 W | 100 mA | 85.0 % | 78 % | 80 °C | -20 ... +50 °C |
| | 500 mA | 20 V | 40.0 V | 20.0 W | 24 W | 110 mA | 83.5 % | 78 % | 85 °C | -20 ... +50 °C |
| | 700 mA | 14 V | 28.5 V | 20.0 W | 24 W | 110 mA | 82.0 % | 75 % | 85 °C | -20 ... +50 °C |

^① Test result at 700 mA.

^② Output current is mean value.

^③ Test result at 25 °C.

1. Standards

EN 55015
EN 60598-1
EN 61000-3-2
EN 61000-3-3
EN 61347-1
EN 61347-2-13
EN 61547
EN 62384

1.1 Glow wire test

according to EN 61347-1 with increased temperature of 850 °C passed.

2. Thermal details and life-time

2.1 Expected life-time

| Expected life-time | | | | |
|-----------------------------------|---------|-----------|---------|---------|
| Type | Current | ta | 40 °C | 50 °C |
| LC 20W 350/500/700mA flexC SR ADV | 350 mA | tc | 70 °C | 80 °C |
| | | Life-time | 50,000h | 30,000h |
| | 500 mA | tc | 75 °C | 85 °C |
| | | Life-time | 50,000h | 30,000h |
| | 700 mA | tc | 75 °C | 85 °C |
| | | Life-time | 50,000h | 30,000h |

The LED Driver is designed for a life-time stated above under reference conditions and with a failure probability of less than 10 %.

3. Installation / wiring

3.1 Circuit diagram

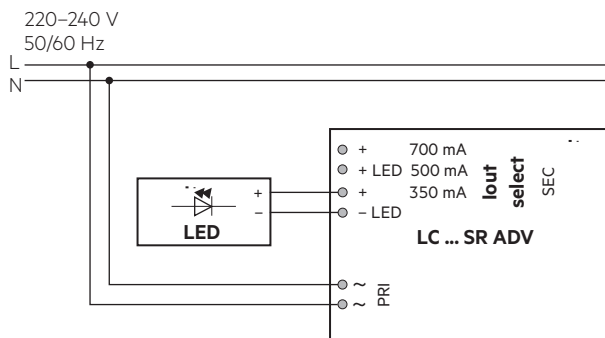

3.2 Wiring type and cross section

The wiring can be in stranded wires with ferrules or solid. For perfect function of the cage clamp terminals the strip length should be 4 – 5 mm for the input terminal.

The max. torque at the clamping screw (M3) is 0.2 Nm.

Input terminal (D2)

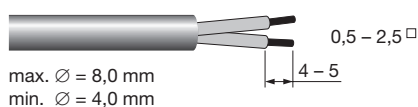

Output terminal (D1)

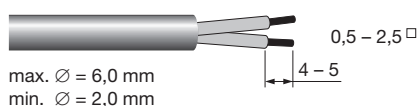

To get a proper working strain relief it is recommended that the cable jacket diameter of the side D2 is 2 mm bigger than the diameter of the side D1. (This can vary if the used cable jacket material varies from side D2 to D1 in pinching property).

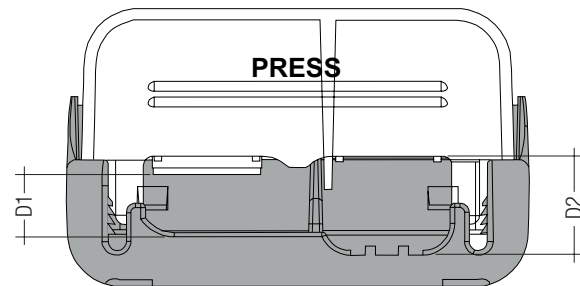

Depending on the used flaps of the terminal following cable jacket diameter difference between the side D2 and D1 terminals is recommended:

| Side D1 | | Side D2 | | Difference D2 - D1 |
|----------------|----------------|-----------|--------------|--------------------|
| Housing bottom | Cover terminal | With flap | Without flap | |
| With flap | Without flap | With flap | Without flap | |
| x | - | x | - | 3.5 mm |
| x | - | x | - | 5.5 mm |
| x | - | - | x | 3.5 mm |
| - | x | x | - | 3.5 mm |
| - | x | - | x | 1.5 mm |
| x | - | - | x | 1.5 mm |
| - | x | x | - | 1.5 mm |
| - | x | - | x | -0.5 mm |

3.3 Fixing conditions

Dry, acidfree, oilfree, fatfree. It is not allowed to exceed the maximum ambient temperature (ta) stated on the device. Minimum distances stated below are recommendations and depend on the actual luminaire. Is not suitable for fixing in corner.

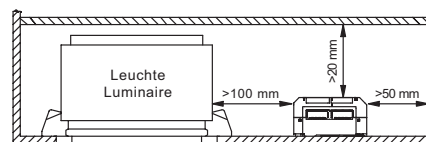

The LED module and all contact points within the wiring must be sufficiently insulated against 3 kV surge voltage.

3.4 Wiring guidelines

- All connections must be kept as short as possible to ensure good EMI behaviour.
- Mains leads should be kept apart from LED Driver and other leads (ideally 5 – 10 cm distance)
- Max. length of output wires is 2 m.
- The secondary wires (LED module) should be routed in parallel to ensure good EMC performance.
- Incorrect wiring can damage LED modules.
- To avoid the damage of the Driver, the wiring must be protected against short circuits to earth (sharp edged metal parts, metal cable clips, louver, etc.).
- The current selection has to be installed in the accordance to the requirement of low voltage installation.

3.5 Replace LED module

1. Mains off
2. Remove LED module
3. Wait for 20 seconds
4. Connect LED module again

Hot plug-in or output switching of LEDs is not permitted and may cause a very high current to the LEDs.

3.6 Current select

For 350 mA current use this terminals:

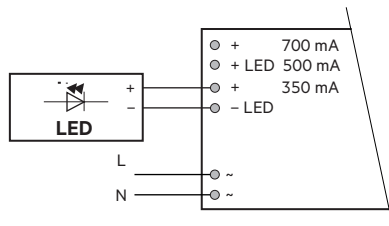

For 500 mA current use this terminals:

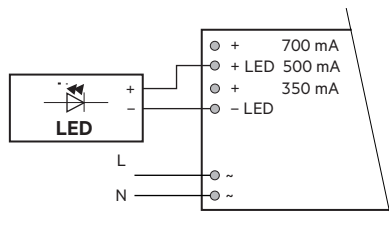

For 700 mA current use this terminals:

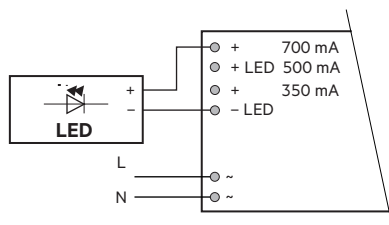

3.7 Mounting of device

Max. torque for fixing: 0.5 Nm/M4

4. Electrical values

Test at 230 V 50 Hz.

4.1 Efficiency vs load

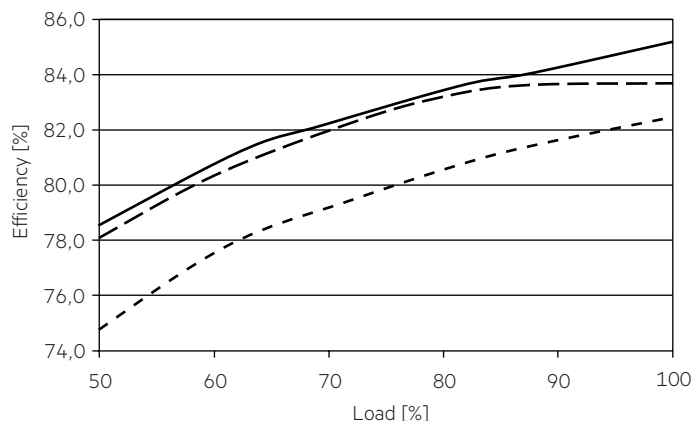

4.2 Power factor vs load

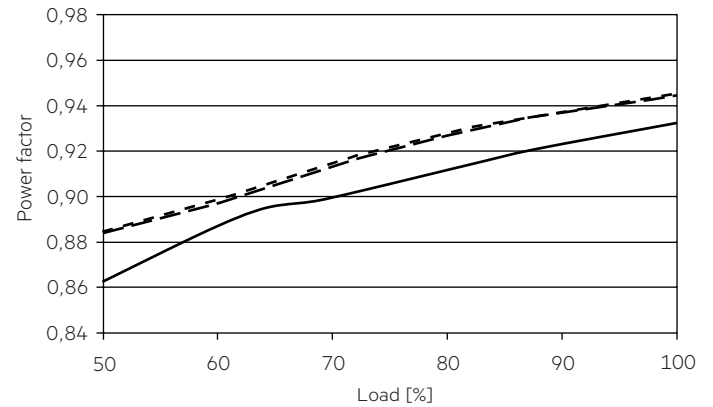

4.3 Input power vs load

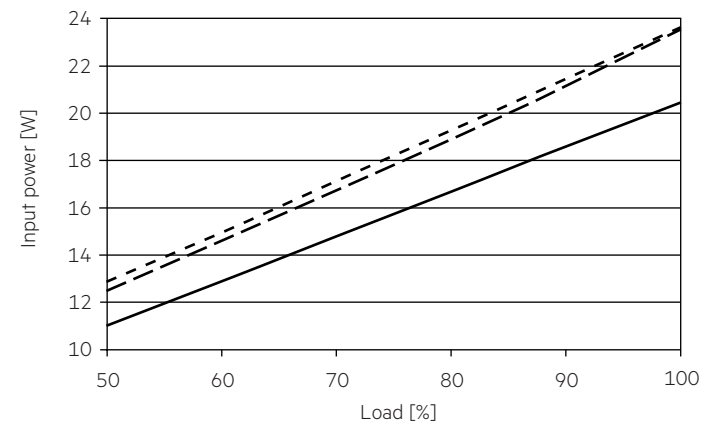

4.4 Input current vs load

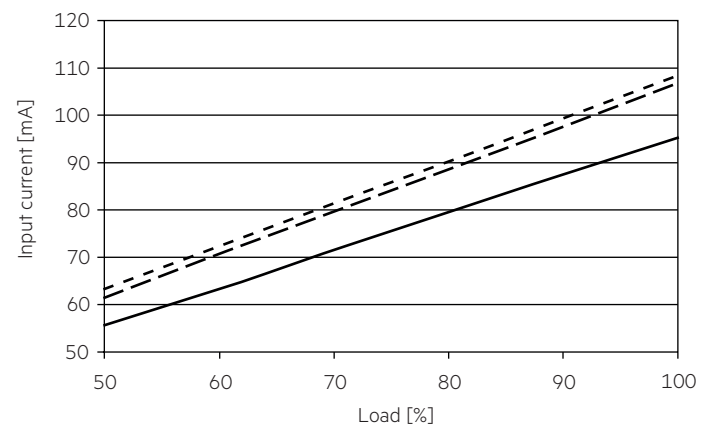

4.5 THD vs load

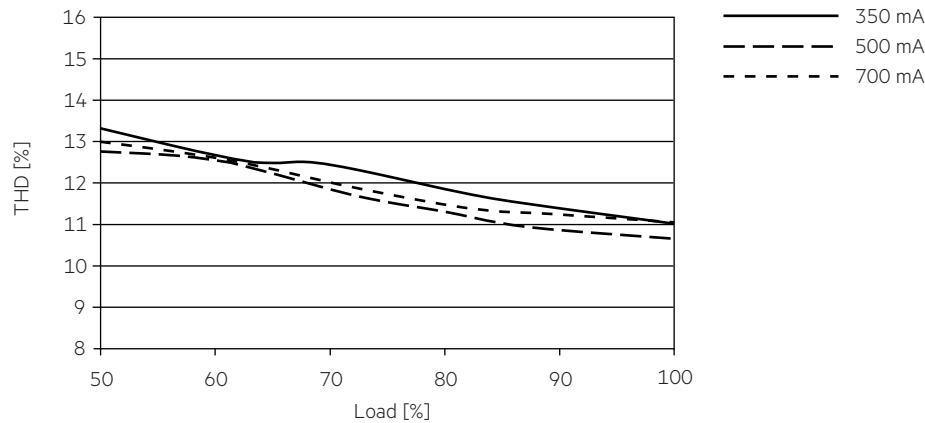

4.6 Maximum loading of automatic circuit breakers in relation to inrush current

| Automatic circuit breaker type | C10 | C13 | C16 | C20 | B10 | B13 | B16 | B20 | Inrush current |
|--|---------------------|---------------------|---------------------|---------------------|---------------------|---------------------|---------------------|---------------------|-----------------------|
| Installation Ø | 1.5 mm ² | 1.5 mm ² | 1.5 mm ² | 2.5 mm ² | 1.5 mm ² | 1.5 mm ² | 1.5 mm ² | 2.5 mm ² | I _{max} Time |
| LC 20W 350/500/700mA flexC SR ADV | 65 | 84 | 104 | 130 | 65 | 84 | 104 | 130 | 10 A 80 µs |

This are max. values calculated out of inrush current! Please consider not to exceed the maximum rated continuous current of the circuit breaker. Calculation uses typical values from ABB series S200 as a reference. Actual values may differ due to used circuit breaker types and installation environment.

4.7 Harmonic distortion in the mains supply (at 230 V / 50 Hz and full load) in %

| | THD | 3. | 5. | 7. | 9. | 11. |
|--|------|------|-----|-----|-----|-----|
| LC 20W 350/500/700mA flexC SR ADV | < 20 | < 11 | < 5 | < 5 | < 4 | < 3 |

5. Functions

5.1 Short-circuit behaviour

In case of a short circuit on the output side (LED) the LED Driver protects itself. After elimination of the short-circuit fault the LED Driver will recover automatically.

5.2 No-load operation

In no-load operation the output voltage will not exceed the specified max. output voltage.

5.3 Overload protection

If the output voltage range is exceeded the LED Driver will protect itself and LED may flicker. After elimination of the overload, the nominal operation is restored automatically.

5.4 Over temperature protection

The LED Driver is protected against temporary thermal overheating. If the temperature limit is exceeded the output current is reduced to limit t_c at a certain level.

6. Miscellaneous

6.1 Insulation and electric strength testing of luminaires

Electronic devices can be damaged by high voltage. This has to be considered during the routine testing of the luminaires in production.

According to IEC 60598-1 Annex Q (informative only!) or ENEC 303-Annex A, each luminaire should be submitted to an insulation test with 500 V_{DC} for 1 second. This test voltage should be connected between the interconnected phase and neutral terminals and the earth terminal.
The insulation resistance must be at least 2 MΩ.

As an alternative, IEC 60598-1 Annex Q describes a test of the electrical strength with 1500 V_{AC} (or 1.414 x 1500 V_{DC}). To avoid damage to the electronic devices this test must not be conducted.

6.2 Conditions of use and storage

Humidity: 5 % up to max. 85 %,
not condensed
(max. 56 days/year at 85 %)

Storage temperature: -40 °C up to max. +80 °C

The devices have to be within the specified temperature range (t_a) before they can be operated.

6.3 Maximum number of switching cycles

All LED Driver are tested with 50,000 switching cycles.
The actually achieved number of switching cycles is significantly higher.

6.4 Additional information

Additional technical information at www.tridonic.com → Technical Data

Guarantee conditions at www.tridonic.com → Services

Life-time declarations are informative and represent no warranty claim.
No warranty if device was opened.